

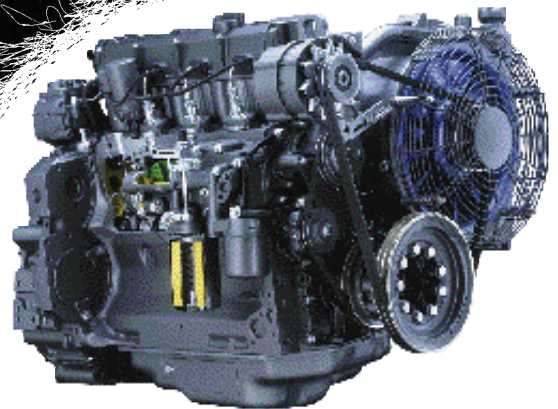

1012. The engine for construction equipment.



41 - 123 kW at 1500 - 2500 min⁻¹



Engines with integrated cooling system

These are the characteristics of the 1012:

- Modern water-cooled 4- and 6-cylinder in-line engines.
- Turbocharging and turbocharging with charge air cooling.
- High-pressure fuel injection up to 1600 bar.
- Electronic engine governor with diagnostic facilities as option.
- Three mounting options for gear-driven hydraulic pumps.
- Compact design, high power-to-volume-ratio.
- Easily accessible service points on one engine side.
- Customer service available worldwide.

These are the benefits for you:

- ▶ Low costs for noise insulation measures. High comfort in driver's cab thanks to low noise level. Low noise emissions, low environmental impact.
- ▶ High operating economy thanks to low fuel consumption, long oil change intervals and low maintenance requirement.
- ▶ Flexible and powerful response to changing operating duties.
- ▶ High productivity through dynamic power development.
- ▶ Low exhaust emission for a clean environment. Meets exhaust regulation EU-RL 97/68.
- ▶ High reliability and long service life even under extreme working conditions.
- ▶ Low installation costs thanks to ready-to-install unit: engine including cooling system.

Engine description

Type of cooling:	Liquid cooling, thermostatically controlled, charge-air-cooled engines with air-to-air charge air cooler*
Crankcase:	High grey cast iron crankcase, for monobloc construction, integrated liners (FM1012), dry liners (FM1012C)
Crankcase breather:	Closed-circuit crankcase breather
Cylinder head:	Grey cast iron block-type cylinder head
Valve arrangement/ timing:	One inlet and one exhaust overhead valve per cylinder, actuated from gear-driven camshaft via tappets, push rods and rocker arms
Piston:	Three-ring piston, two compression rings and one oil scraper ring
Piston cooling:	Oil-cooled with spray nozzles
Connecting rod:	Forged steel rod
Crankshaft bearings:	Tri-metal plain bearings
Crankshaft:	With integral counterweights
Camshaft:	Forged steel shaft
Lubrication system:	Forced-feed circulation lubrication with gear pump
Lube oil cooler:	Oil cooler integrated in coolant circuit
Lubre oil filter:	Paper-type microfilter as replaceable-cartridge full flow filter
Fuel pump/governor:	Single injection pumps for each cylinder integrated in crankcase Mechanical centrifugal governor (standard); electronic engine governor (EMR) optional
Fuel lift pump:	Integrated in V-belt tensioner
Injection nozzle:	Five-hole nozzle
Fuel filter:	Replaceable cartridge
Alternator:	Three-phase alternator 12 V or 24 V
Starter motor:	12 V or 24 V
Heating system:	Optional connection for cab heating to engine cooling circuit
Options:	Intake manifold, exhaust manifold, turbocharger positions, air compressor, hydraulic pump installation positions, SAE 2/3/4/ flywheel housings, flywheels, 12 V or 24 V electrics, oil pans, cold-starting facilities

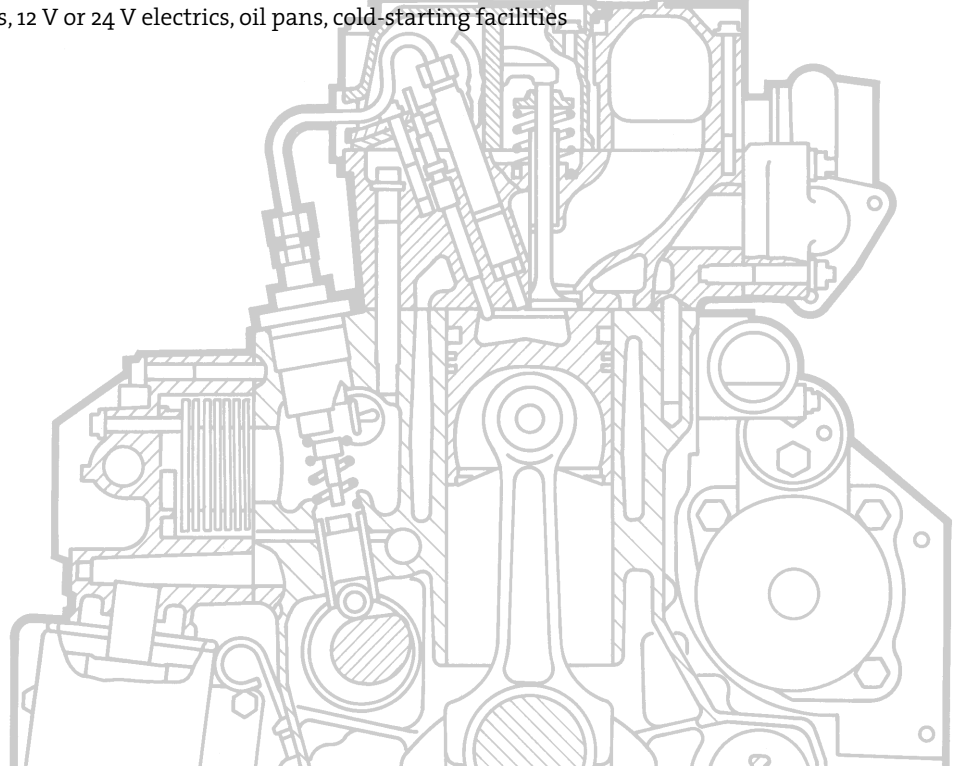

► Technical data

Engine type		BF4M1012	BF4M1012C	BF6M1012	BF6M1012C
Number of cylinders		4	4	6	6
Bore/stroke	mm	94/115	94/115	94/115	94/115
Displacement	l	3.19	3.19	4.79	4.79
Compression ratio		17.5	17.5	17.5	17.5
Max. rated speed	min ⁻¹	2500	2500	2500	2500
Mean piston speed	m/s	9,58	9,58	9,58	9,58
Power ratings for construction equipment engines¹⁾					
Power ratings for automotive engines ²⁾ kW		65	82	98	123
at speed	min ⁻¹	2500	2500	2500	2500
Mean effective pressure	bar	9.77	12.33	9.82	12.33
Power ratings for industrial engines ³⁾					
highly intermittent operation	kW	62	78	93	118
at speed	min ⁻¹	2500	2500	2500	2500
Mean effective pressure	bar	9.32	11.73	9.32	11.83
intermittent operation ³⁾	kW	58	74	88	111
at speed	min ⁻¹	2500	2500	2500	2500
Mean effective pressure	bar	8.72	11.13	8.82	11.13
Max. torque	Nm	298	376	447	564
at speed	min ⁻¹	1500	1500	1500	1500
Minimum idle speed	min ⁻¹	650	650	650	650
Specific fuel consumption ⁴⁾	g/kWh	208	200	208	200
Weight to DIN 70020, Part 7A ⁵⁾	kg	380	400	495	520

► Model designation

BF 6 M 1012 C

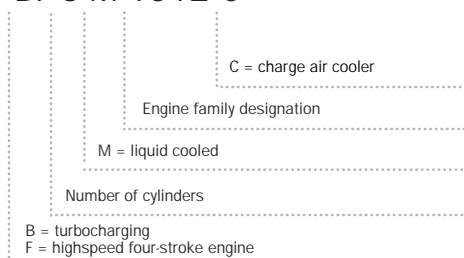

- 1) Power ratings at flywheel without deduction of fan power requirement.
- 2) To ISO 1585, EG-RL80/1269/EWG and EG-RL88/195/EWG.
- 3) To ISO 3046/1 (IFN), DIN 6271 fuel stop power.
- 4) Specific fuel consumption based on diesel fuel with a specific gravity of 0.835 kg/dm³ at 15°C.
- 5) Without charge air cooler

The values given in this data sheet are for information purposes only and not binding.
The information given in the offer is decisive.

► Dimensions

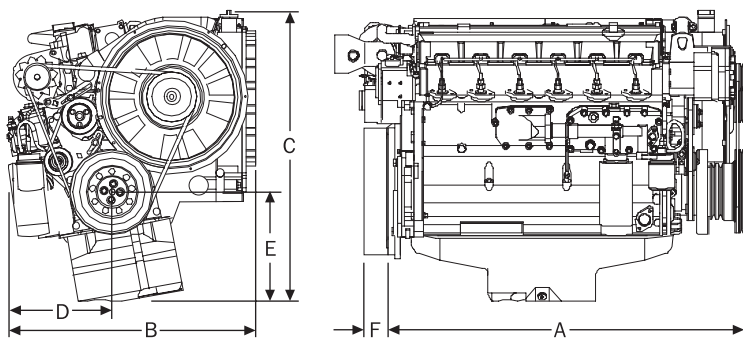

Engine		A	B	C	D	E	F
BF4M1012	mm	752	665	741	331	235	122
BF4M1012C*	mm	912	752	840	331	235	122
BF6M1012	mm	1060	765	830	331	320	122
BF6M1012C*	mm	1170	811	941	331	320	122

* dimensions without charge air cooler • side-mounted turbocharger optional

► Standard engines

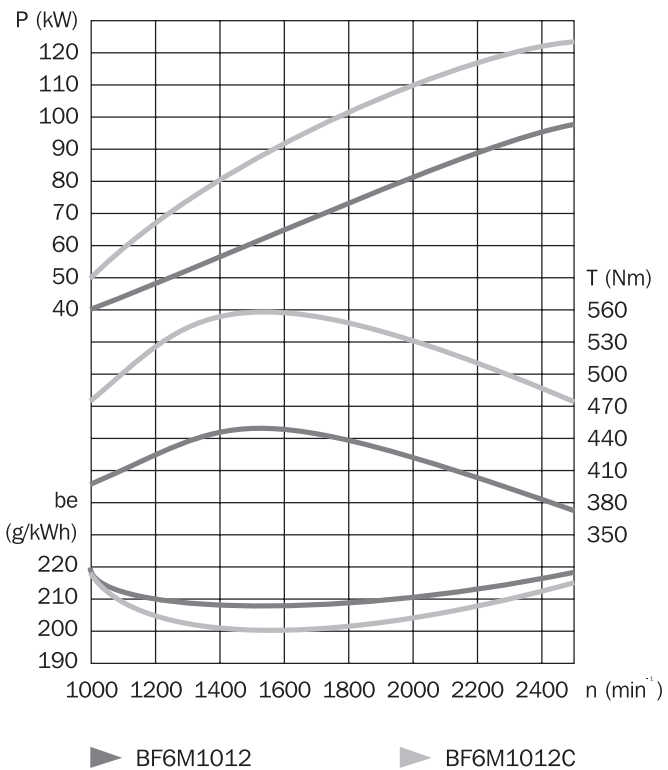
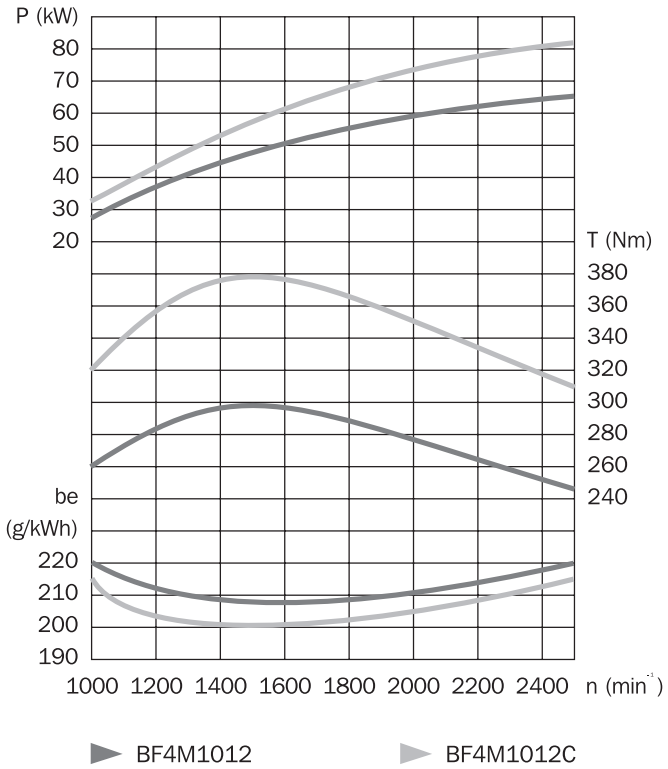



Knowing it's DEUTZ.

DEUTZ AG
<http://www.deutzmexico.com>