



1013. The engine for construction equipment.



63 - 190 kW at 1500 - 2300 min⁻¹



Engines with integrated cooling system

These are the characteristics of the 1013:

- Modern water-cooled 4- and 6-cylinder in-line engines.
- Turbocharging and turbocharging with charge air cooling.
- High-pressure fuel injection up to 1600 bar.
- Electronic engine governor with diagnostic facilities as option.
- Three separate mounting options for gear-driven hydraulic pumps.
- Compact design, high power-to-volume ratio.
- Easily accessible service points on one engine side.
- Customer service available worldwide.

These are the benefits for you:

- ▶ Low cost for noise insulation measures. High comfort in driver's cabin thanks to low noise level. Low noise emissions, low pollution of environment.
- ▶ High operating economy thanks to low fuel consumption, long oil change intervals and low maintenance costs.
- ▶ Flexible and powerful response to changing operating duties.
- ▶ High productivity through dynamic power development.
- ▶ Low exhaust emission for a clean environment. Meets exhaust regulation EU-RL 97/68.
- ▶ High reliability and long service life even under extreme working conditions.
- ▶ Low installation costs thanks to ready to install unit: engine including cooling system.

Engine description

Type of cooling:	Liquid cooling, thermostatically controlled, charge-air-cooled engines with air-to-air charge air cooler*
Crankcase:	High grey cast iron crankcase, for monobloc construction,
Crankcase breather:	Closed-circuit crankcase breather
Cylinder head:	Grey cast iron block-type cylinder head
Valve arrangement/ timing:	One inlet and one exhaust valve per cylinder, actuated from gear-driven camshaft via tappets, push rods and rocker arms
Piston:	Three-ring piston, two compression rings and one oil scraper ring
Piston cooling:	Oil cooled with spray nozzles
Connecting rod:	Forged steel rod
Crankshaft bearings:	Tri-metal plain bearings
Crankshaft:	With integral counterweights
Camshaft:	Forged steel shaft
Lubrication system:	Forced-feed circulation lubrication with gear pump
Lube oil cooler:	Oil cooler integrated in coolant circuit
Lube oil filter:	Paper-type microfilter as replaceable-cartridge full flow filter
Injection pump/ governor:	Single injection pumps for each cylinder integrated in crankcase Mechanical centrifugal governor (standard); electronic governor (EMR) optional
Fuel lift pump:	Integrated in V-belt tensioner
Injection nozzle:	Six-hole nozzle
Fuel filter:	Replaceable cartridge
Alternator:	Three-phase alternator 12 V or 24 V
Starter motor:	12 V or 24 V
Heating system:	Optional connection for cab heating to engine cooling circuit
Options:	Intake manifold, exhaust manifold, turbocharger positions, air compressor, hydraulic pump installation positions, SAE 2/3/4/ flywheel housings, flywheels, 12 V or 24 V electrics, oil pans, cold-starting facilities

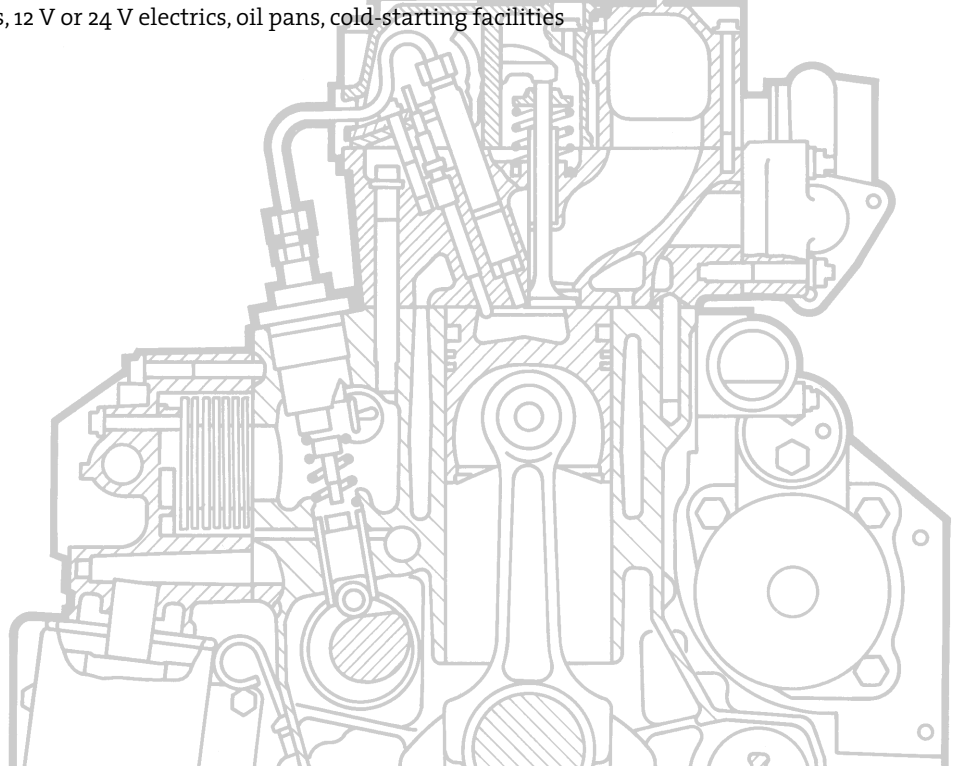

► Technical data

Engine type		BF4M1013	BF4M1013C	BF6M1013	BF6M1013C	BF6M1013CP
Number of cylinders		4	4	6	6	6
Bore/stroke	mm	108/130	108/130	108/130	108/130	108/130
Displacement	l	4.76	4.76	7.14	7.14	7.14
Compression ratio		17.6	17.6	17.6	17.6	17.6
Max. rated speed	min ⁻¹	2300	2300	2300	2300	2300
Mean piston speed	m/s	9.97	9.97	9.97	9.97	9.97
Power ratings for construction equipment engines¹⁾						
Power ratings for automotive engines ²⁾	kW	93	115	141	170	190
at speed	min ⁻¹	2300	2300	2300	2300	2300
Mean effective pressure	bar	10.4	12.59	10.29	12.41	13.87
Power ratings for industrial engines³⁾						
highly intermittent operation	kW	88	112	133	161	181
at speed	min ⁻¹	2300	2300	2300	2300	2300
Mean effective pressure	bar	9.86	12.27	9.71	11.75	13.18
intermittent operation ³⁾	kW	84	104	126	153	171
at speed	min ⁻¹	2300	2300	2300	2300	2300
Mean effective pressure	bar	9.42	11.39	9.2	11.17	12.48
Max torque	Nm	464	572	697	847	946
at speed	min ⁻¹	1400	1400	1400	1400	1400
Minimum idle speed	min ⁻¹	650	650	650	650	650
Specific fuel consumption ⁴⁾	g/kWh	200	195	200	195	195
Weight to DIN 70020, Part 7A ⁵⁾	kg	530	550	676	702	702

► Model designation

BF 6 M 1013 C

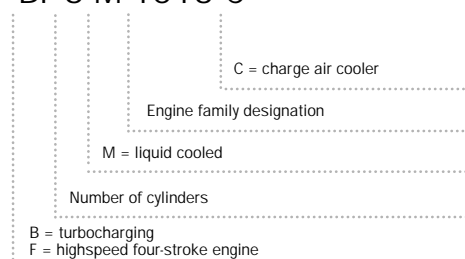

- 1) Power ratings at flywheel without deduction fan power requirement.
- 2) To ISO 1585, EG-RL80/1269/EWG and EG-RL88/195/EWG.
- 3) To ISO 3046/1 (IFN), DIN 6271 fuel stop power.
- 4) Specific fuel consumption based on diesel fuel with a specific gravity of 0.835 kg/dm³ at 15°C.
- 5) without charge air cooler

The values given in this data sheet are for information purposes only and not binding. The information given in the offer is decisive.

► Dimensions

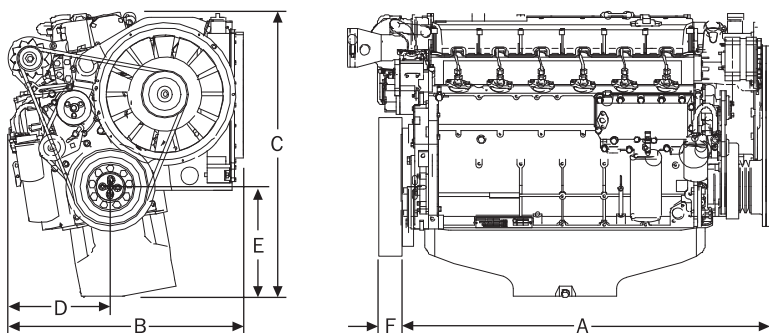

Engine		A	B	C	D	E	F
BF4M1013	mm	898	760	790	338	295	122
BF4M1013C*	mm	898	760	790	338	295	122
BF6M1013	mm	1158	760	845	338	345	122
BF6M1013C*	mm	1158	760	845	338	345	122
BF6M1013CP*)	mm	1158	760	845	338	345	122

* dimensions without charge air cooler • side-mounted turbocharger optional

► Standard engines

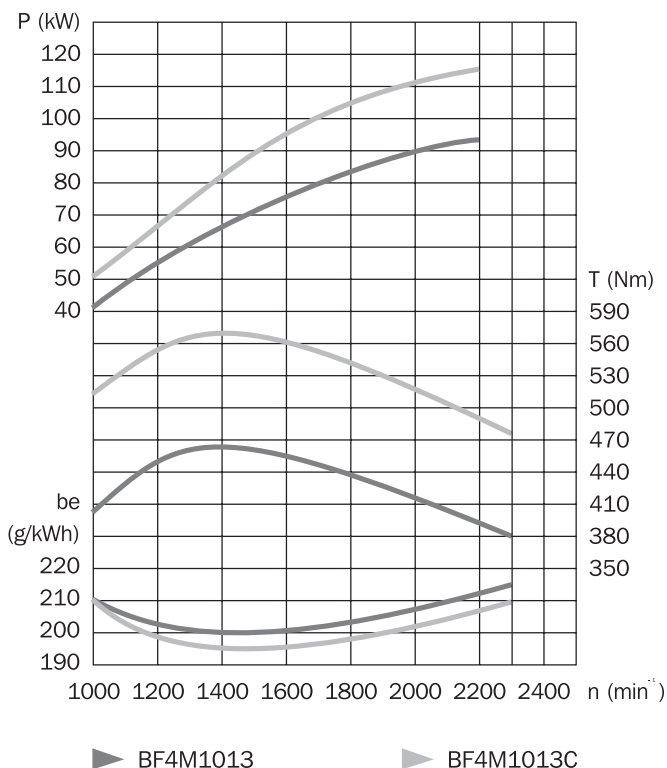

► Standard engines

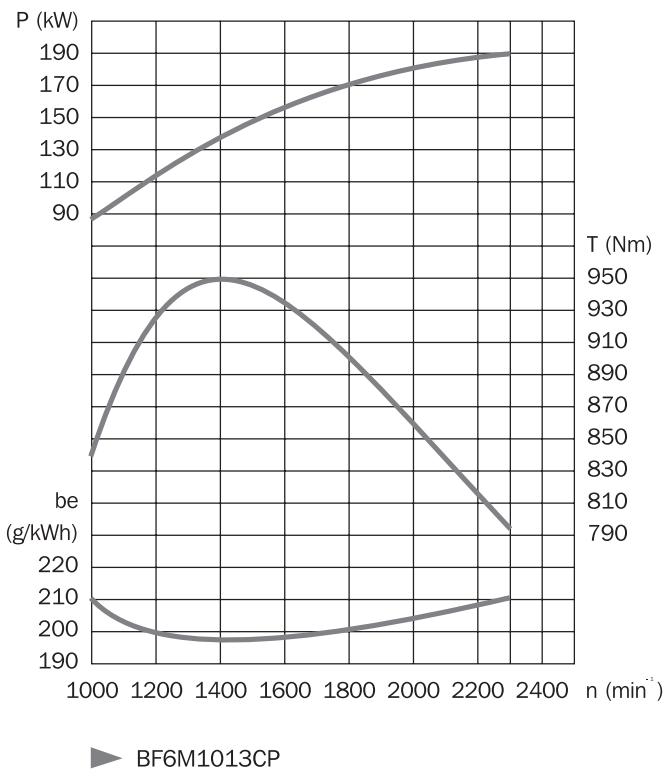
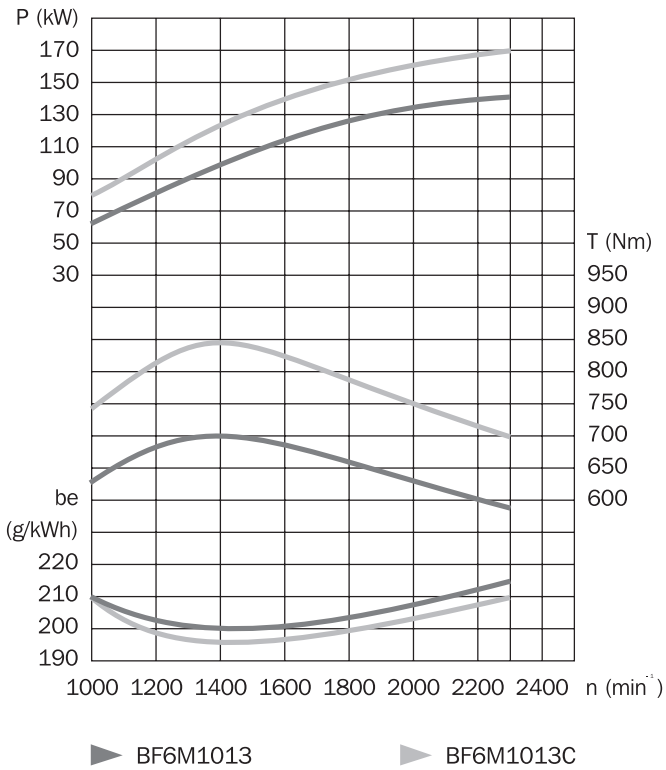



Knowing it's DEUTZ.

DEUTZ AG
<http://www.deutzmexico.com>