

912W. The underground mining engine.

47 - 93 hp at 2500 rpm



These are the characteristics of the 912W:

Air-cooled four stroke 3-, 4-, 5- and 6- cylinder in-line engines.

DEUTZ-two-stage combustion.

PTOs via gear, flywheel and v-belt pulley.

Extremely compact design.

High torque at low speed.

Modular system with single cylinder arrangement and high degree of parts commonality.

Customized component system with many different peripheral parts.

Your benefits:

- ▶ Fast response to load changes.
- ▶ Minimal environmental impact. All engines are certificated acc. to MSHA.
- ▶ Low operating costs thanks to lower fuel consumption, low specific ventilation requirements and long maintenance intervals with reduced maintenance requirements.
- ▶ Compact design saves installation space and thus construction costs.
- ▶ Easy-to-install unit (engine with integrated cooling system).

► Technical data

Engine type		F3L912W	F4L912W	F5L912W	F6L912W
Number of cylinder		3	4	5	6
Bore/stroke	mm	102/125	102/125	102/125	102/125
Displacement	l	3.064	4.086	5.107	6.128
Compression ratio		22	22	22	22
Max. rated speed	rpm	2800	2800	2800	2800
Mean piston speed	m/s	11.6	11.6	11.6	11.6

Power ratings for underground mining engines

Power ratings ¹⁾	hp	47	62	76	93
at speed ²⁾	rpm	2500	2500	2500	2500
Mean effective pressure	bar	5.48	5.40	5.36	5.40
Max. torque	Nm	149	198	249	298
at speed	rpm	1550	1550	1550	1550
Minimum idle speed	rpm	650	650	700	650
Spec. fuel consumption ³⁾	g/kWh	230	230	230	230
Weight to DIN 70020, Part 7A ⁴⁾	kg	277	300	380	410

► Dimensions

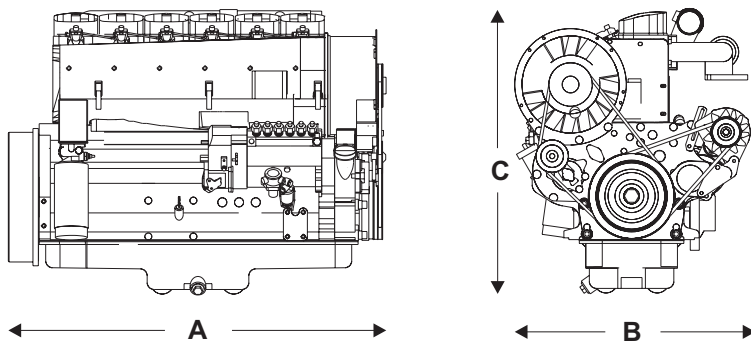

- 1) Power ratings without deduction fan power requirements, incl. cooling system. Ratings as per ISO 3046.
- 2) Power ratings for non-mentioned speeds upon request.
- 3) At optimal operating point. Spec. fuel consumption acc. to the power ratings in the schedule: 255 g/kWh. Specific fuel consumption based on diesel fuel with a specific gravity of 0,835 kg/dm³ at 15°C.
- 4) Without starter motor/alternator, radiator and liquids, however with flywheel and flywheel housing and complete integrated cooling system.



Engine		Length	Width	Height
F3L912W	mm	697	679	796
F4L912W	mm	807	679	796
F5L912W	mm	954	679	833
F6L912W	mm	1084	679	806

<http://www.deutzmexico.com>